

MARSDEN

Marsden M-165 User Manual



Please take time to read these instructions before starting to use the scale.

Contents

Introduction	2
Product Specification	2
Safety Instructions	3
Explanation of Graphic Symbols	4
Power Supply and Low Battery	5
Operation: Basic Functions	6
Operation: Advanced Functions	8
Assembling the Column	10
Attaching the Height Measure	11
Levelling the Scale	12
EMC Guidance and Manufacturer's Declaration	13
Error Messages	15
Manufacturer's Declaration of Conformity	15

Introduction

Thank you for purchasing a professional gym weighing scale. Ideal for areas of heavy traffic and guaranteed accurate weight readings. Continue reading for instructions on how to use the device and company contact information.

Product Specification

Model	M-165
Capacity/Division	250kg x 100g
Weight of Scale	Approximately 8kg
Units of Measure	Kg/St
Function Keys	ON/ZERO/OFF, UNIT, SEND, HOLD/BMI, TARE/BSA
Stabilization Time	1-2 Seconds
Operating Temperature	5 °C to 35 °C
Power Supply	6x 1.5V AA batteries or 12V 1A adaptor (UE24WCP1 – 120100SPA)
Indicator Display	3cm display with 5 active digits
Dimensions	Base: 310mm x 310mm x 83mm Indicator: 174mm x 107.6mm x 50mm
Warranty	4 year

Safety Instructions

Before putting the device into use, please read with care the information given in this user manual, which contains important instructions for proper installation, use and maintenance of the device.

Marsden and/or the manufacturer shall not be liable for damages arising from failure to heed the following instructions:

- When using electrical components under increased safety requirements, always comply with appropriate regulations.
- Inappropriate installation/use will render the warranty null and void.
- Ensure the voltage marked on the power supply unit matches your mains supply.
- This device is designed for use indoors only.
- Observe the permissible ambient temperatures for use.
- The device meets the requirements for electromagnetic compatibility. Do not exceed the maximum values specified in the applicable standards.
- Batteries should be kept away from small children. If swallowed, promptly seek urgent medical assistance.

If you have any problems with this scale, please contact Marsden/your local dealer/your service partner.

If a serious incident occurs in relation to this device, it should be reported to the manufacturer and the competent authority of the Member State in which the user and/or patient is established.

Cleaning

- We recommend using alcohol-based wipes or similar when cleaning the scale.
- Please do not use corrosive liquids, large amounts of water or high-pressure washers.
- Always disconnect the scale from the mains power supply before cleaning.

Maintenance

- The scale does not require any routine maintenance. However, we recommend checking the scale's accuracy at regular intervals. If any inaccuracies occur, please contact your local dealer or service partner.
- If you are in the UK, service contracts are available from Marsden to keep your scale accurate and reliable for longer. Call 01709 364296 for more information.















Disposing of the Scale

- This product should not be treated as regular household waste but should be handed in to an electrical/electronic equipment recycling centre.
- You can obtain further details from your local council, your municipal waste disposal company or from where you purchased the product.
- Alternatively, you can return this product to Marsden – we will recycle this free of charge,

Intended Use

- This scale is intended for use to determine the weight of patients, supported by professional personnel and in rooms intended for carrying out healthcare. The weighing value can be read after a stable weighing value has been obtained. Before use, the scale must be checked by an authorised person to ensure it's in a suitable condition.
- Device is intended to measure one subject at a time.

Explanation of Graphic Symbols

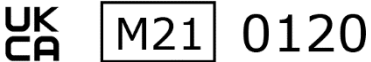
	Caution, consult accompanying documents before use		Separate collection for waste of electrical and electronic equipment, in accordance with Directive 2002/96/EC
	Manufacturer of medical device		Manufacturing year of medical device
	Carefully read user manual before installation and usage, and follow instructions for use.		Medical electrical equipment with Type B applied part
	Device catalogue number		Authorized representative in the European Community
	Manufacturer's batch or lot number		Device is a medical device
	Serial number		Unique Device Identifier
		Device conforms to 93/42/EEC as amended by 2007/47/EC Medical Device Directive. Four digit number refers to Notified Body.	
		Device complies with International Organization of Legal Metrology (Class III) requirements (verified models only)	
		<p>Device complies with EC directives (verified models only)</p> <p>M: Conformity label in compliance with Directive 2014/31/EU for non-automatic weighing instruments</p> <p>19: Year in which conformity verification was performed and the CE label was applied. (ex: 19=2019)</p> <p>0122: Refers to Notified Body for metrology</p>	
		<p>Device complies with UK Regulation.</p> <p>M: Non-Automatic Weighing Instruments Regulations 2016.</p> <p>21: Year in which conformity verification was performed and the CE label was applied. (ex: 21=2021)</p> <p>0120: Refers to the Approved Body for metrology</p>	

Power Supply & Low Battery



The indicator uses power from 6x AA batteries, or can be powered from the mains via the adaptor.

Make sure the batteries are installed in the battery box of the indicator. Alternatively, plug the adaptor (12V 1A) into the port on the side of the scale.

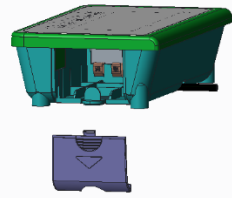
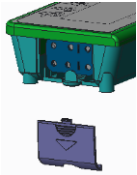
Installing Batteries

	<p>Remove the battery cover.</p>
	<p>Remove the battery case and insert batteries, ensuring they are properly installed.</p>
	<p>Install the battery housing.</p>
	<p>Refit the battery cover.</p>

Switching on the Scale

	<p>Press the ON/ZERO/OFF button firmly.</p>
	<p>When the scale shows 0.0 on the display you are ready to start weighing.</p>

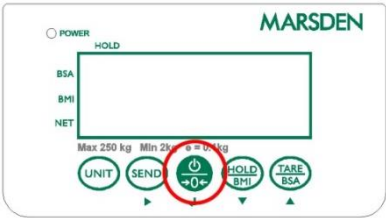

Switching off the Scale

 <p>The image shows the Marsden scale's control panel. The display is blank. The buttons are labeled: UNIT, SEND, ON/ZERO/OFF (circled in red), HOLD/BMI, and TARE/BSA. The display area has labels for POWER, HOLD, BSA, BMI, and NET. Below the display, it says 'Max 250 kg Min 2kg e = 0.1g'.</p>	<p>Hold the ON/ZERO/OFF button for three seconds when the scale is turned on. The scale will power down.</p>
--	--

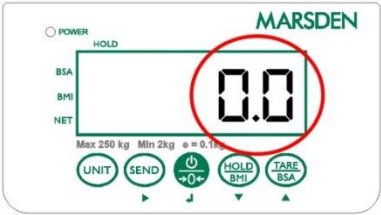
Setting the Scale to Zero

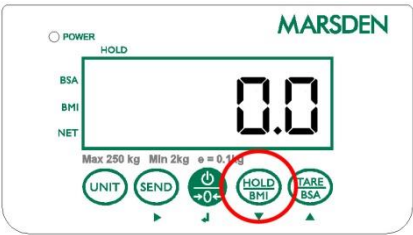

 <p>The image shows the Marsden scale's control panel. The display shows '0.2'. The buttons are labeled: UNIT, SEND, ON/ZERO/OFF (circled in red), HOLD/BMI, and TARE/BSA. The display area has labels for POWER, HOLD, BSA, BMI, and NET. Below the display, it says 'Max 250 kg Min 2kg e = 0.1g'.</p>	<p>If the display shows a reading other than 0.0 when nothing is on the scale, it can be reset to zero.</p> <p>Press ON/ZERO/OFF once.</p>
 <p>The image shows the Marsden scale's control panel. The display shows '0.0'. The buttons are labeled: UNIT, SEND, ON/ZERO/OFF (circled in red), HOLD/BMI, and TARE/BSA. The display area has labels for POWER, HOLD, BSA, BMI, and NET. Below the display, it says 'Max 250 kg Min 2kg e = 0.1g'.</p>	<p>The scale will return to 0.0.</p>

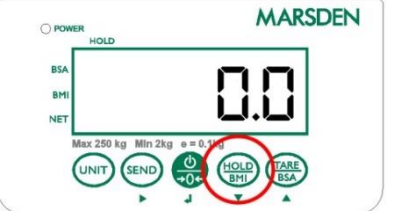
Hold Function

 <p>The image shows the Marsden scale display with the digital readout at 0.0. The 'HOLD' indicator is lit. The 'HOLD/BMI' button on the control panel is circled in red.</p>	<p>Press the HOLD/BMI button once, either whilst the patient is stood on the scale or before they step onto the scale.</p>
 <p>The image shows the Marsden scale display with the digital readout at 78.0. The 'HOLD' indicator is lit. The 'HOLD/BMI' button on the control panel is circled in red.</p>	<p>After a few seconds the scale will lock on the person's weight. When the patient leaves the scale, the weight will remain on the display.</p>
 <p>The image shows the Marsden scale display with the digital readout at 0.0. The 'HOLD' indicator is lit. The 'HOLD/BMI' button on the control panel is circled in red.</p>	<p>Press HOLD/BMI again to disable the Hold function and return the scale to 0.0.</p>

Note: If the weight reading remains on the display for more than five minutes, the Hold function will automatically disable and the display will return to 0.0. If another patient steps on the scale whilst a held weight reading is being displayed, the Hold function will be disabled.

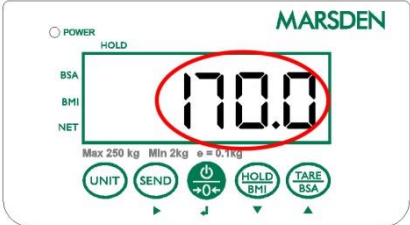

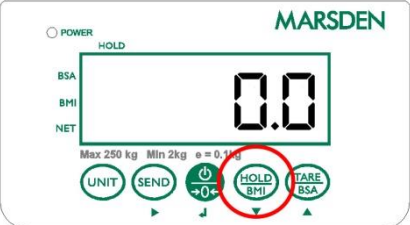
Body Mass Index (BMI) Function

 <p>The image shows the Marsden scale display in BMI mode. The display shows '78.0'. The 'BSA' indicator is lit, and the 'BMI' indicator is also lit. The 'NET' indicator is not lit. The display also shows 'Max 250 kg Min 2kg e = 0.1kg'. The buttons 'UNIT', 'SEND', 'ON/ZERO/OFF', 'HOLD/BMI', and 'TARE/BSA' are visible at the bottom.</p>	<p>The patient should first stand on the scale.</p>
 <p>The image shows the Marsden scale display in BMI mode. The display shows '170.0'. The 'BSA' indicator is lit, and the 'BMI' indicator is also lit. The 'NET' indicator is not lit. The display also shows 'Max 250 kg Min 2kg e = 0.1kg'. The buttons 'UNIT', 'SEND', 'ON/ZERO/OFF', 'HOLD/BMI', and 'TARE/BSA' are visible at the bottom. The first digit '1' is flashing.</p>	<p>Hold down the HOLD/BMI button to enter BMI mode. The scale will enter height setting mode and the extreme left digit will flash.</p>
 <p>The image shows the Marsden scale display in BMI mode. The display shows '180.0'. The 'BSA' indicator is lit, and the 'BMI' indicator is also lit. The 'NET' indicator is not lit. The display also shows 'Max 250 kg Min 2kg e = 0.1kg'. The buttons 'UNIT', 'SEND', 'ON/ZERO/OFF', 'HOLD/BMI', and 'TARE/BSA' are visible at the bottom. The first two digits '18' are flashing.</p>	<p>Enter the height by using the TARE/BSA button to decrease the value and HOLD/BMI button to increase the value. To move to the next digit, press SEND.</p>
 <p>The image shows the Marsden scale display in BMI mode. The display shows '24.0'. The 'BSA' indicator is lit, and the 'BMI' indicator is also lit. The 'NET' indicator is not lit. The display also shows 'Max 250 kg Min 2kg e = 0.1kg'. The buttons 'UNIT', 'SEND', 'ON/ZERO/OFF', 'HOLD/BMI', and 'TARE/BSA' are visible at the bottom. The first digit '2' is flashing.</p>	<p>To confirm the height hold down the ON/ZERO/OFF button, after a few seconds the display will alternate between weight, height and BMI.</p>
 <p>The image shows the Marsden scale display in normal weighing mode. The display shows '0.0'. The 'BSA' indicator is lit, and the 'NET' indicator is also lit. The 'BMI' indicator is not lit. The display also shows 'Max 250 kg Min 2kg e = 0.1kg'. The buttons 'UNIT', 'SEND', 'ON/ZERO/OFF', 'HOLD/BMI', and 'TARE/BSA' are visible at the bottom.</p>	<p>To exit BMI mode and return to normal weighing mode, hold down the HOLD/BMI button.</p>

Body Surface Area (BSA)

 <p>The image shows the Marsden scale display with the BSA function selected. The display shows '56.0'. The 'TARE/BSA' button is circled in red.</p>	<p>After calculating BMI, you can then calculate BSA. After going through the first four steps on the previous page steps to calculate BMI, press TARE/BSA and Body Surface Area will be displayed.</p>
---	---

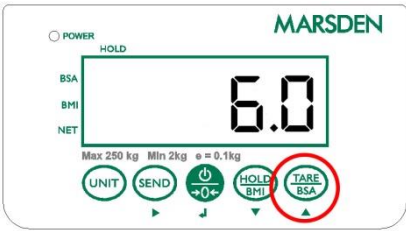
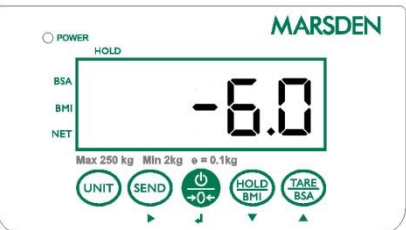
Tare Function

 <p>The image shows the Marsden scale display with the BSA function selected. The display shows '6.0'. The 'TARE/BSA' button is circled in red.</p>	<p>Place the item/s you wish to deduct from the reading (such as a pair of shoes) on the scale and press TARE/BSA.</p>
 <p>The image shows the Marsden scale display with the BSA function selected. The display shows '-6.0'. The 'TARE/BSA' button is circled in red.</p>	<p>Remove the item/s, and the scale will show a minus reading.</p>
 <p>The image shows the Marsden scale display with the BSA function selected. The display shows '176.0'. The entire display area is circled in red.</p>	<p>Weigh the patient as normal and the negative weight reading will be deducted from the total weight.</p>

Assembling the Column (M-165 only)

Assembling the M-165's column should ideally be carried out by two people.

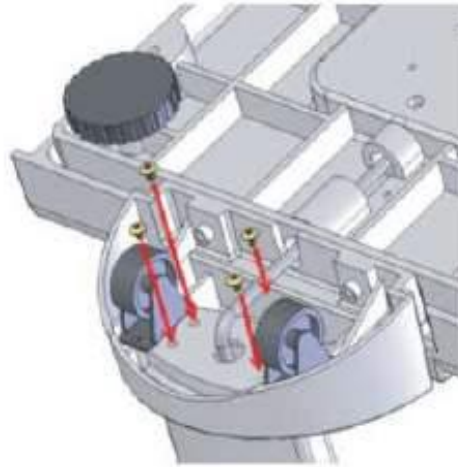

Holding both the column and the base, ensuring all wiring is tucked inside the column housing, turn the scale over so that the column can be screwed to the base from the underside of the base.

Use the four screws provided, screwing them carefully into the four holes as shown in the drawing.

Before Use

- 1) Place the scale on a firm and level surface
- 2) Unwind the levelling feet until they make contact with the ground.

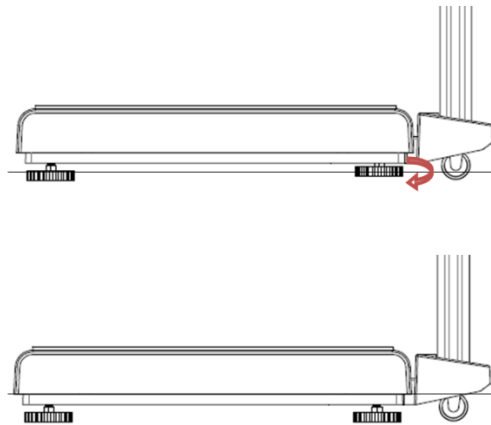

- 3) Ensure that all four of the levelling feet and the wheels are firmly on the ground and that the spirit level bubble is located in the center as shown below:

Correct:

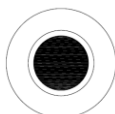

Incorrect:

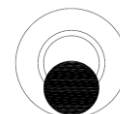

Attaching the Height Measure (M-165 only)

The M-165 can be purchased with a height measure. If you did not purchase your M-160 with a height measure, it is also available separately (model HM-201M).

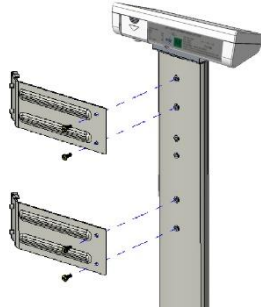

Using the four M5*0.8*9 screws provided, mount the two brackets onto the column of the M-165.

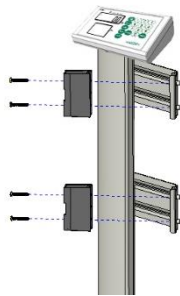

Using the four M5*0.8*25 screws provided, screw the black blocks onto the mounting brackets.



Using the two M6*1.0*10 screws provided, screw the HM-201M to the black blocks.

To measure a person's height, retract the height rod and position the head stop accordingly.

For M-165 spare parts, call Marsden on 01709 364296.

EMC Guidance and Manufacturer's Declaration

Guidance and manufacturer's declaration-electromagnetic emissions		
The SCALE M-165 is intended for use in the electromagnetic environment specified below. The customer or the user of the SCALE M-165 should assure that it is used in such an environment.		
Emission test	Compliance	Electromagnetic environment-guidance
RF emissions CISPR 11	Group 1	The SCALE M-165 uses RF energy only for its internal function. Therefore, its RF emissions are very low and are not likely to cause any interference in nearby electronic equipment.
RF emissions CISPR 11	Class B	The SCALE M-165 is suitable for use in all establishments, including domestic establishments and those directly connected to the public low-voltage power supply network that supplies buildings used for domestic purposes.
Harmonic emissions IEC 61000-3-2	Class A	
Voltage fluctuations /flicker emissions IEC 61000-3-3	Compliance	







Guidance and manufacturer's declaration-electromagnetic immunity			
The M-165 intended for use in the electromagnetic environment specified below. The customer or the user of the M-165 should assure that it is used in such an environment.			
Immunity test	IEC 60601 test level	Compliance level	Electromagnetic environment-guidance
Electrostatic discharge(ESD) IEC 61000-4-2	± 8 kV contact ± 2 kV, ± 4 kV, ± 8 kV, ± 15 kV air	± 6 kV contact ± 8 kV air	Floors should be wood, concrete or ceramic tile. If floors are covered with synthetic material, the relative humidity should be at least 30%
Electrical fast transient/burst IEC 61000-4-4	± 2kV for power supply lines + 1kV for input/output lines	± 2kV for power supply lines Not applicable	Mains power quality should be that of a typical commercial or hospital environment.
Surge IEC 61000-4-5	± 1kV line(s) to line(s) ± 2kV line(s) to earth	± 1kV differential mode Not applicable	Mains power quality should be that of a typical commercial or hospital environment.
Voltage Dips, short interruptions and voltage variations on power supply input lines IEC 61000-4-11	0% UT for 0,5 cycle 0% UT for 1 cycle 70% UT(30% dip in UT) for 25 cycles 0% UT for 5 s	<5% UT(>95% dip in UT) for 0,5 cycle 40% UT(60% dip in UT) for 5 cycles 70% UT(30% dip in UT) for 25 cycles <5% UT(>95% dip in UT) for 5 s	Mains power quality should be that of a typical commercial or hospital environment. If the user of the M-165 requires continued operation during power mains interruptions, it is recommended that the M-165 be powered from an uninterruptible power supply or a battery.
Power frequency(50/60 Hz) magnetic field IEC 61000-4-8	30 A/m	3 A/m	The M-165 power frequency magnetic fields should be at levels characteristic of a typical location in a typical commercial or hospital environment.
NOTE UT is the a.c. mains voltage prior to application of the test level.			



Guidance and manufacturer's declaration-electromagnetic immunity			
The M-165 is intended for use in the electromagnetic environment specified below. The customer or the user of the SCALE M-165 should assure that it is used in such and environment.			
Immunity test	IEC 60601 test level	Compliance level	Electromagnetic environment-guidance
Conducted RF IEC 61000-4-6	3 Vrms 150 KHz to 80 MHz 6 V in ISM bands between 0,15 MHz and 80 MHz 80 % AM at 1 kHz	3 Vrms	Portable and mobile RF communications equipment should be used no closer to any part of the M-165 including cables, than the recommended separation distance calculated from the equation applicable to the frequency of the transmitter. Recommended separation distance: $d = 1,2 \sqrt{P}$ $d = 1,2 \sqrt{P}$ 80MHz to 800 MHz $d = 2,3 \sqrt{P}$ 800MHz to 2,7 GHz Where P is the maximum output power rating of the transmitter in watts (W) according to the transmitter manufacturer and d is the recommended separation distance in metres (m). Field strengths from fixed RF transmitters, as determined by an

			<p>electromagnetic site survey^a, should be less than the compliance level in each frequency range^b.</p> <p>Interference may occur in the vicinity of equipment marked with the following symbol:</p> 
Radiated RF IEC 61000-4-3	3 V/m 80MHz to 2,7 GHz	3 V/m	
<p>NOTE1 At 80 MHz and 800 MHz, the higher frequency range applies.</p> <p>NOTE2 These guidelines may not apply in all situations. Electromagnetic propagation is affected by absorption and reflection from structures, objects and people.</p> <p>a Field strengths from fixed transmitters, such as base stations for radio (cellular/cordless) telephones and land mobile radios, amateur radio, AM and FM radio broadcast and TV broadcast cannot be predicted theoretically with accuracy. To assess the electromagnetic environment due to fixed RF transmitters, an electromagnetic site survey should be considered. If the measured field strength in the location in which the M-165 is used exceeds the applicable RF compliance level above, the M-165 should be observed to verify normal operation. If abnormal performance is observed, additional measures may be necessary, such as re-orienting or relocating the M-165.</p> <p>b Over the frequency range 150 kHz to 80 MHz, field strengths should be less than 3 V/m.</p>			

Recommended separation distance between portable and mobile RF communications equipment.			
The M-165 is intended for use in an electromagnetic environment in which radiated RF disturbances are controlled. The customer or the user of the M-165 can help prevent electromagnetic interference by maintaining a minimum distance between portable and mobile RF communications equipment (transmitters) and the M-165 as recommended below, according to the maximum output power of the communications equipment.			
Rated maximum output power of transmitter	Separation distance according to frequency of transmitter m		
W	150 kHz to 80 MHz $d = 1,2\sqrt{P}$	80 MHz to 800 MHz $d = 1,2\sqrt{P}$	800 MHz to 2,7 GHz $d = 2,3\sqrt{P}$
0,01	0,12	0,12	0,23
0,1	0,38	0,38	0,73
1	1,2	1,2	2,3
10	3,8	3,8	7,3
100	12	12	23
For transmitters rated at a maximum output power not listed above, the recommended separation distance d in metres (m) can be estimated using the equation applicable to the frequency of the transmitter, where p is the maximum output power rating of the transmitter in watts (W) according to the transmitter manufacturer.			
NOTE1 At 80 MHz and 800 MHz, the separation distance for the higher frequency range applies.			
NOTE2 These guidelines may not apply in all situations. Electromagnetic propagation is affected by absorption and reflection from structures, objects and people.			

Error Messages

<p>Low Battery The scale's alkaline AA type batteries are flat; please replace the batteries.</p>	
<p>Overload This indicates that the scale's load sensor(s) have been overloaded. Reduce the loading and retry.</p>	
<p>Counting Error</p> <ol style="list-style-type: none"> 1. The signal from the load cells is too high. Please remove any weight from the scale and try to power on again. If the scale continues to show the error message, it indicates a fault with the electronics or wiring. 2. The signal from the load cells is too low. Please remove any weight from the scale and try again. If the scale continues to show the error message, it indicates a fault with the electronics or wiring. 	 
<p>High/Low Zero Count</p> <ol style="list-style-type: none"> 1. The scale is above its zero range. Please remove any weight from the scale and power on again. If the scale continues to show the error message, it indicates a fault with the electronics. 2. The scale is below its zero range. Check there is nothing jammed underneath the scale and power on again. If the scale continues to show the error message, it indicates a fault with the electronics. 	 
<p>EEPROM Error This indicates there is a fault with the scale's software and is normally caused by a fault with the load cell or wiring. Contact your local service representative.</p>	

<p>EU Authorized Representative:</p>	 <p>Obelis s.a. Bd Général Wahis, 53 B-1030 Brussels Belgium</p>
<p>Distributor:</p>	<p>MARSDEN</p> <p>Marsden Weighing Machine Group Ltd, Unit 1, Genesis Business Park, Sheffield Road, Rotherham, UK, S60 1DX</p>
<p>EU Importer:</p>	<p>MARSDEN</p> <p>Marsden Weighing Machine Group Europe Ltd, The Black Church, St. Mary's Place, Dublin 7, Dublin, Ireland, D07 P4AX</p>
<p>Manufactured by:</p>	 <p>Charder Electronic Co., Ltd. No.103, Guozhong Rd., Dali Dist., Taichung City 41262, Taiwan (R.O.C.)</p>

MARSDEN

Unit 1, Genesis Business Park,
Sheffield Road, Rotherham,
S60 1DX

Telephone: + 44 (0) 1709 364296

Version 2.0